

Unit Specifications:

- Compressor: (1) Scroll, Copeland or Equivalent
- Condensers: (1) Copper Brazed with 316L plates
- Evaporators: (1) Aluminum Micro Channel (Electrocoating Optional)
- Potable Water Pump: (1) 1/2 HP SST Volute, Standard, 150 PSI Max Working Pressure
- Design Flow Rate: 18.7 GPM (10 HP), 24 GPM (15 HP) @ 15 °F TD, 100 F Air / 50% RH
- Max External Head @ Design: 24.5 ft (10 HP), 14.8 ft (15 HP)
- Source Air Fan: 1.34 HP Axial ECM, 1550 RPM
- Minimum Required Airflow: 4,700 CFM, 0.0" H2O Available
- Control: Microprocessor (PLC)
- Frame: 304 SST with Cabinet (316 SST Cabinet Optional)
- Refrigerant Type: 134a, 450 PSI Max Working Pressure
- Refrigerant Charge: 11.5 lbs (10 HP), 11 lbs (15 HP)
- Dry Weight: 885 lbs (10 HP), 895 lbs (15 HP)
- Crated Weight: 1155 lbs (10 HP), 1165 lbs (15 HP)
- Crated Dimensions: 51" x 44" x 83" (L x W x H)
- Average Sound Pressure @ 1M: 76 dB(A)

*VALUES ARE APPROXIMATE AND FOR REFERENCE ONLY

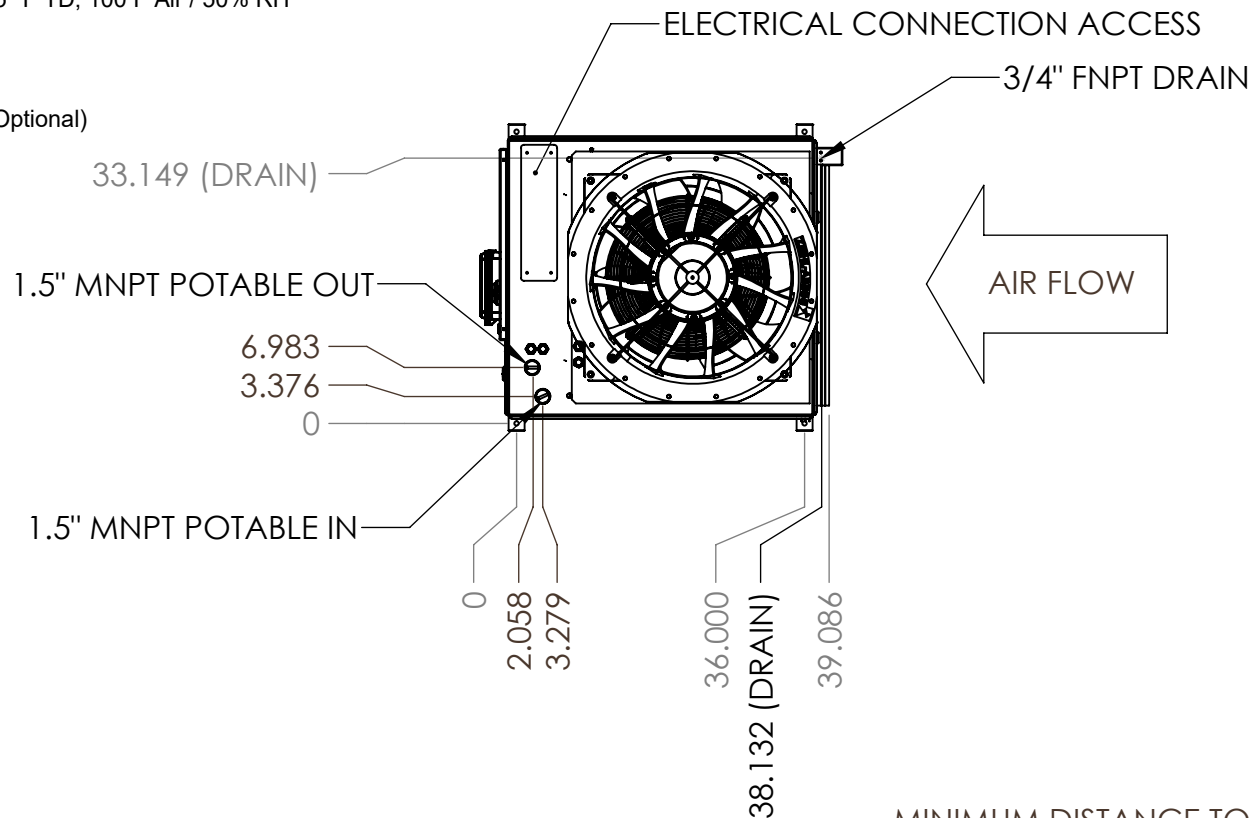
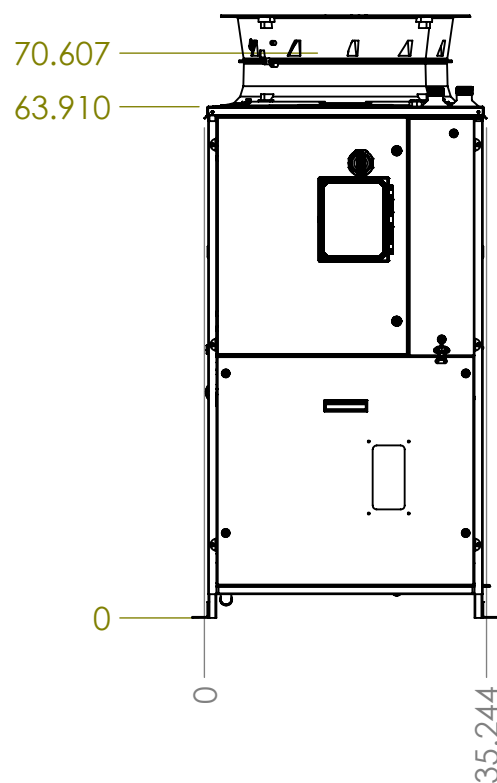
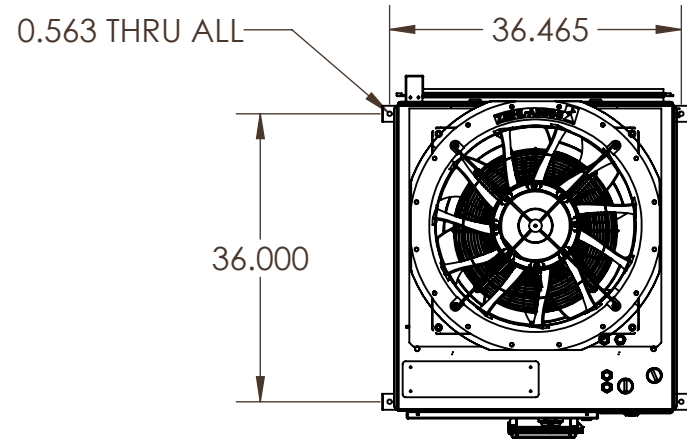

MINIMUM DISTANCE TO OBSTRUCTION FROM EVAPORATOR INLET; RECOMMENDED 36" CLEARANCE FOR BEST PERFORMANCE

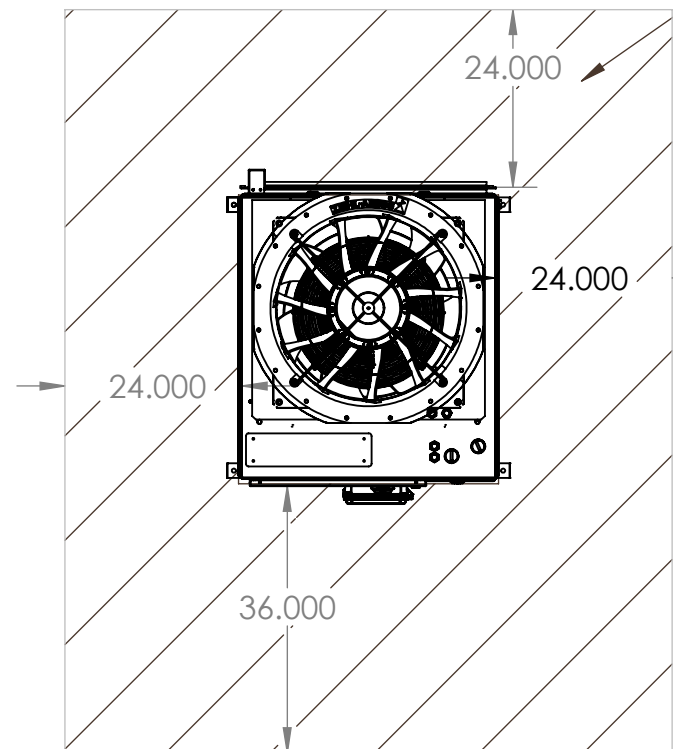

RECOMMENDED SERVICE CLEARANCE FOR SINGLE UNIT

MINIMUM DISTANCE TO OBSTRUCTION FROM AXIAL OUTLET IS 30". LESS THAN THIS MAY REDUCE PERFORMANCE OR INCREASE NOISE LEVELS

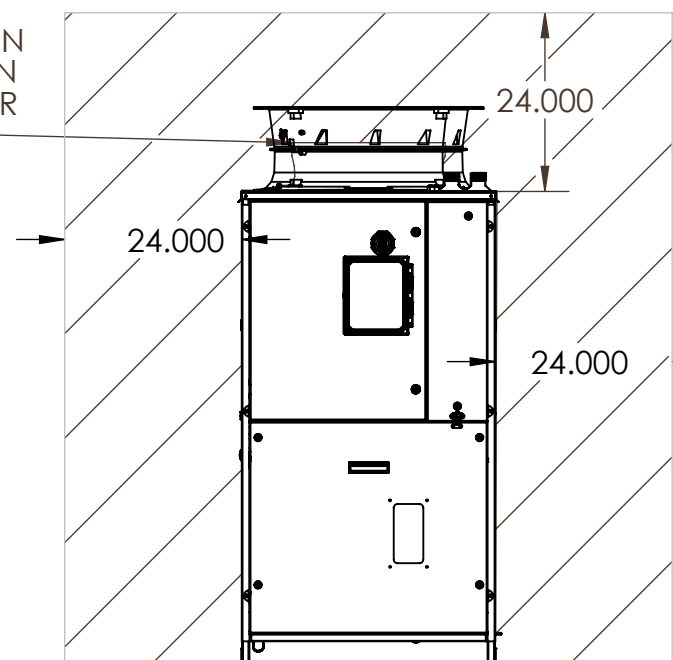

PROPRIETARY AND CONFIDENTIAL THE INFORMATION CONTAINED IN THIS DRAWING IS THE SOLE PROPERTY OF COLMAC INDUSTRIES. ANY REPRODUCTION IN PART OR AS A WHOLE WITHOUT THE WRITTEN PERMISSION OF COLMAC INDUSTRIES IS PROHIBITED.

REV. No.	REV STATUS
SHT. No.	OF SHEET

UNLESS OTHERWISE SPECIFIED: DIMENSIONS ARE IN INCHES TOLERANCES: FRACTIONAL: ±1/16 ANGULAR: MACH ±1° BEND ±1° TWO PLACE DECIMAL ±0.03 THREE PLACE DECIMAL ±0.031		CONTRACT NO.	COLMAC INDUSTRIES 401 N. Lincoln, Colville, Washington 99114 (509)684-4505	
DRAWN BY KLR		DATE	TITLE: CXA 10-15 SUBMITTAL DRAWING WITH AXIAL FAN	
ENGINEER		DATE	SIZE	DWG. NO.
NEXT ASSY		USED ON	REV	
APPLICATIONS		SOLIDWORKS	AUTOCAD	
DO NOT SCALE DRAWING		SCALE: 1:24	UNIT WT.	SHEET 1 OF 3

Unit Specifications:

- Compressor: (1) Scroll, Copeland or Equivalent
- Condensers: (1) Copper Brazed with 316L plates
- Evaporators: (1) Aluminum Micro Channel (Electrocoating Optional)
- Potable Water Pump: (1) 1/2 HP SST Volute, Standard, 150 PSI Max Working Pressure
- Design Flow Rate: 18.7 GPM (10 HP), 24 GPM (15 HP) @ 15 °F TD, 100 F Air / 50% RH
- Max External Head @ Design: 24.5 ft (10 HP), 14.8 ft (15 HP)
- Source Air Fan: 4.8 HP Backwards Curved ECM, 1550 RPM
- Minimum Required Airflow: 5,000 CFM, 2.7" H2O Available
- Control: Microprocessor (PLC)
- Frame: 304 SST with Cabinet (316 SST Cabinet Optional)
- Refrigerant Type: 134a, 450 PSI Max Working Pressure
- Refrigerant Charge: 11.5 lbs (10 HP), 11 lbs (15 HP)
- Dry Weight: 980 lbs (10 HP), 990 lbs (15 HP)
- Crated Weight: 1350 lbs (10 HP), 1370 lbs (15 HP)
- Crated Dimensions: 51" x 44" x 96" (L x W x H)
- Average Sound Pressure @ 1M: 76 dB(A)

*VALUES ARE APPROXIMATE AND FOR REFERENCE ONLY

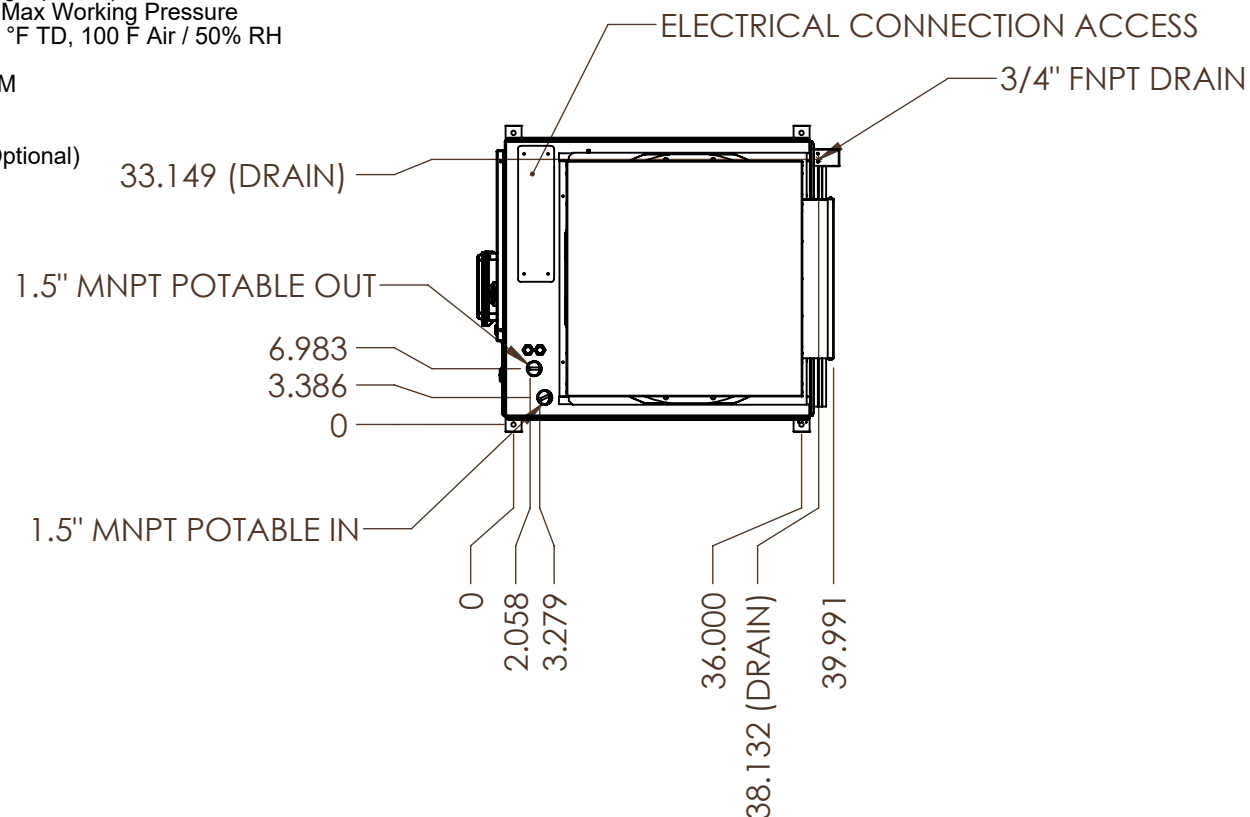
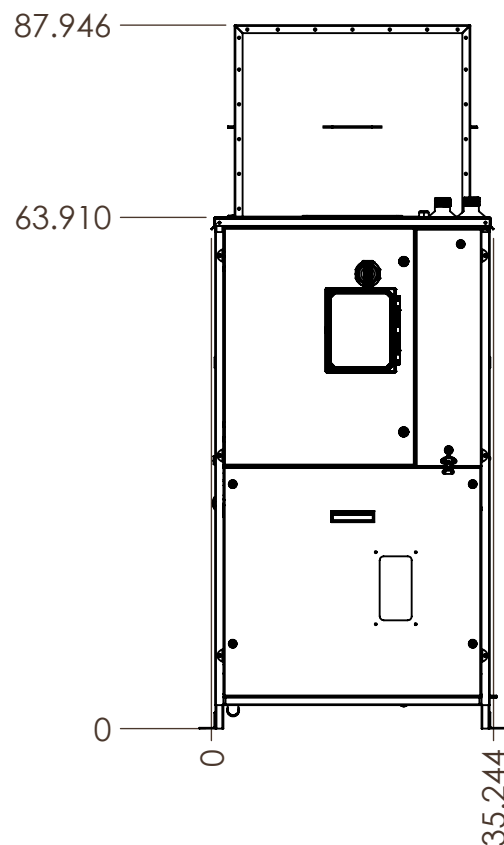
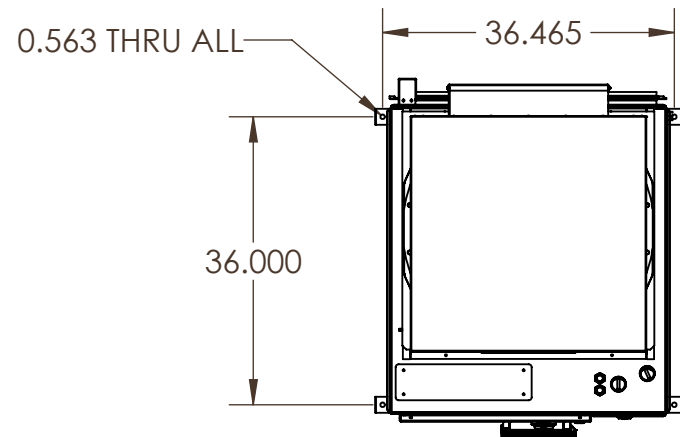

MINIMUM DISTANCE TO OBSTRUCTION FROM EVAPORATOR INLET;
RECOMMENDED 36" CLEARANCE FOR BEST PERFORMANCE

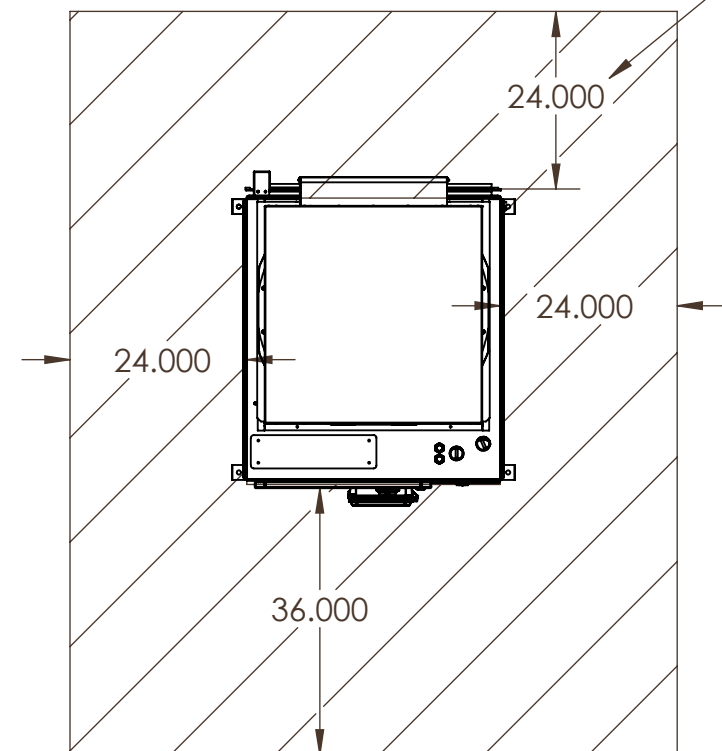

RECOMMENDED SERVICE CLEARANCE FOR SINGLE UNIT

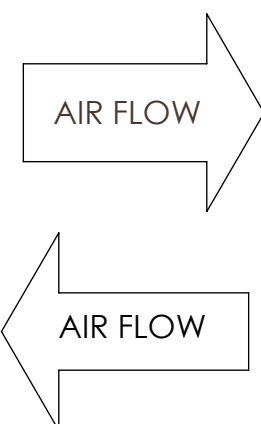
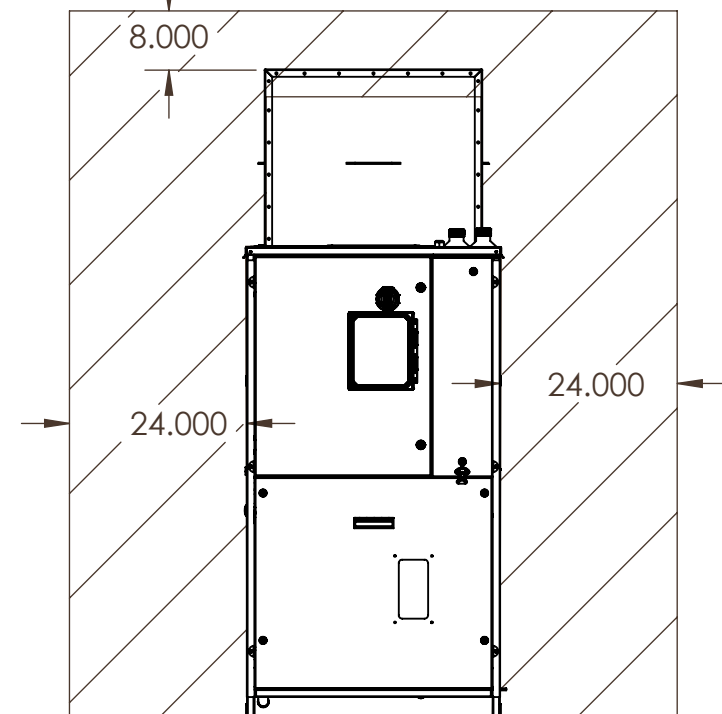

PROPRIETARY AND CONFIDENTIAL
THE INFORMATION CONTAINED IN THIS DRAWING IS THE SOLE PROPERTY OF COLMAC INDUSTRIES. ANY REPRODUCTION IN PART OR AS A WHOLE WITHOUT THE WRITTEN PERMISSION OF COLMAC INDUSTRIES IS PROHIBITED.

REV. No.	REV STATUS
SHT. No.	OF SHEET

UNLESS OTHERWISE SPECIFIED: DIMENSIONS ARE IN INCHES TOLERANCES: FRACTIONAL: ±1/16 ANGULAR: MACH ±1° BEND ±1° TWO PLACE DECIMAL ±0.03 THREE PLACE DECIMAL ±0.031		CONTRACT NO.	COLMAC INDUSTRIES 401 N. Lincoln, Colville, Washington 99114 (509)684-4505	
DRAWN BY KLR	DATE	TITLE: CXA 10-15 SUBMITTAL DRAWING WITH CENTRIFUGAL FAN		
ENGINEER	DATE	SIZE	DWG. NO.	REV
NEXT ASSY	USED ON	B 1010CXA-0015		
APPLICATIONS		DO NOT SCALE DRAWING		SCALE: 1:24 UNIT WT. SHEET 2 OF 3

8 7 6 5 4 3 2 1

F

E

D

C

B

A

F

E

D

C

B

A

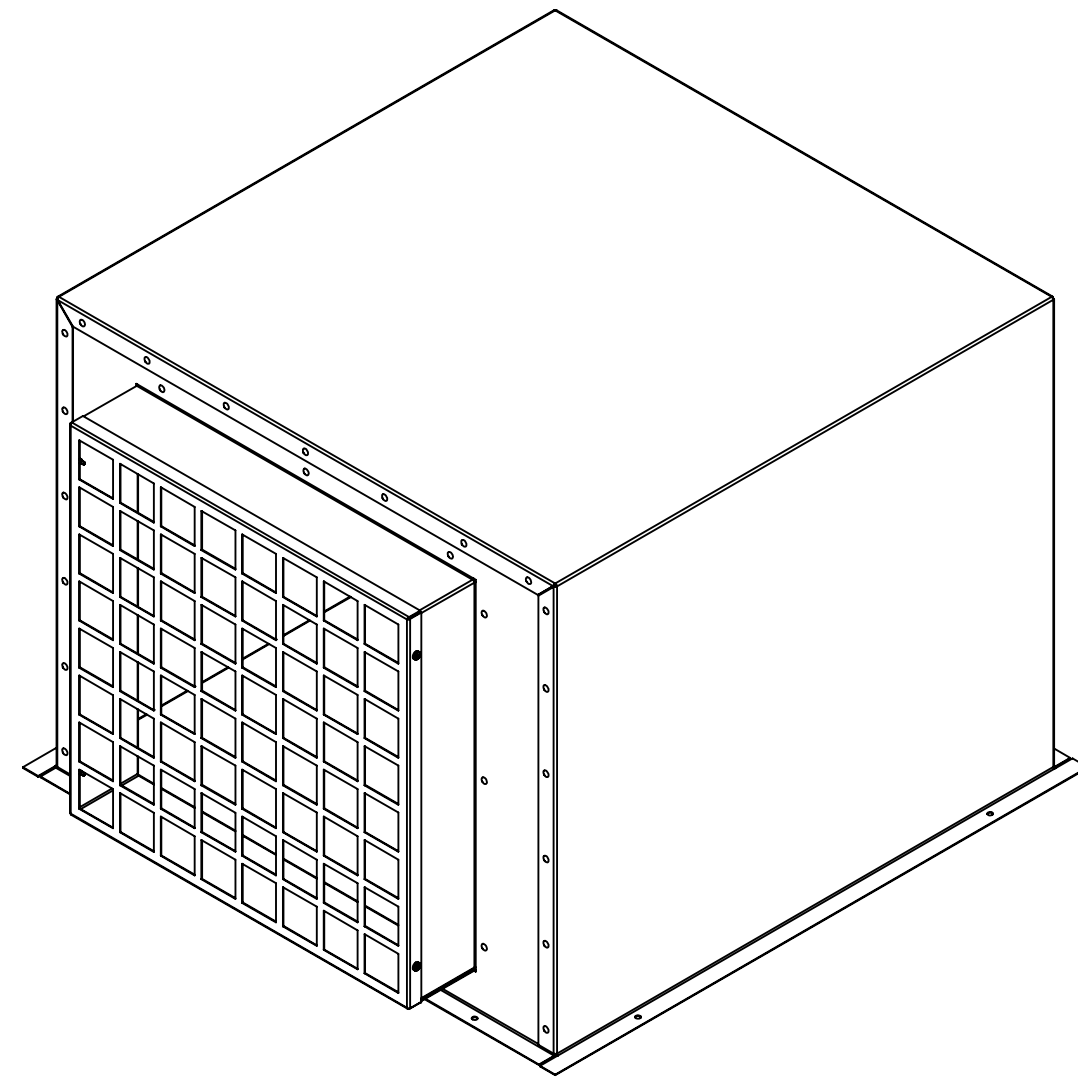
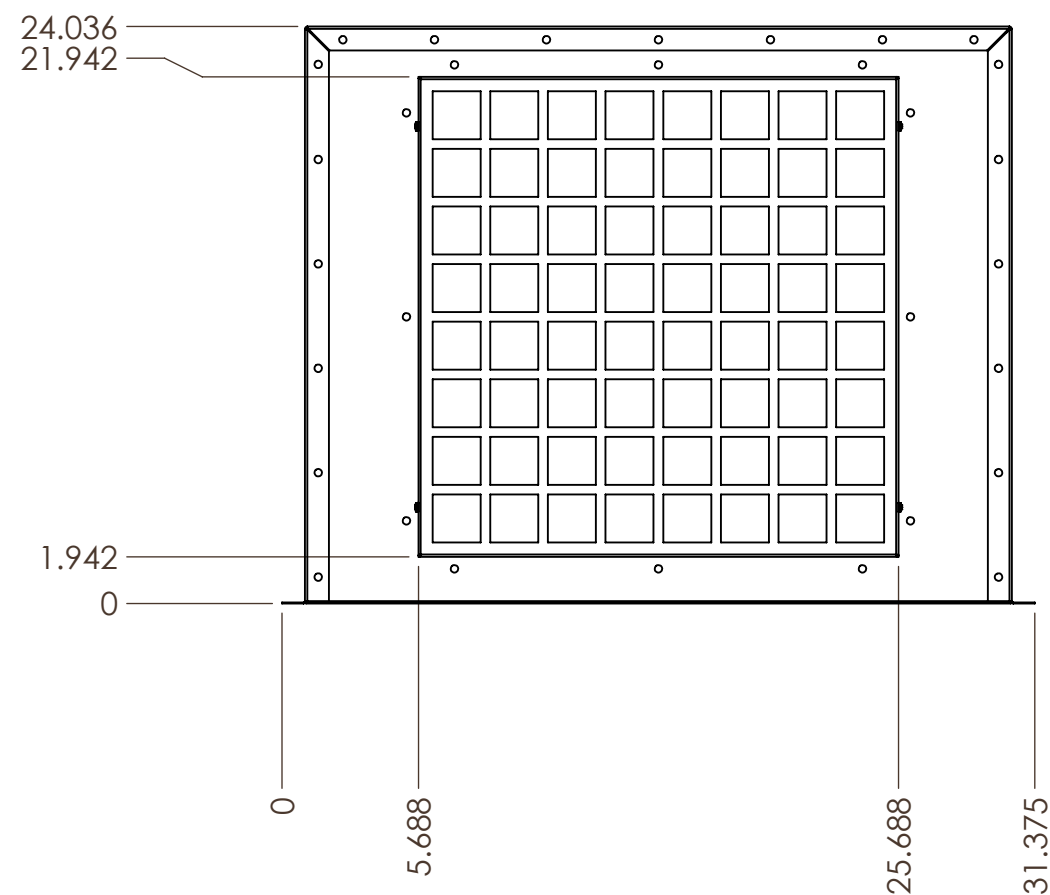

NOTE: PLENUM CAN BE ROTATED IN 90° INCREMENTS TO EXHAUST AIR IN ANY HORIZONTAL DIRECTION

EXHAUST GRILLE TO BE REMOVED BEFORE CONNECTING DUCTING

PROPRIETARY AND CONFIDENTIAL
THE INFORMATION CONTAINED IN THIS DRAWING IS THE SOLE PROPERTY OF COLMAC INDUSTRIES. ANY REPRODUCTION IN PART OR AS A WHOLE WITHOUT THE WRITTEN PERMISSION OF COLMAC INDUSTRIES IS PROHIBITED.

REV. No.	REV STATUS OF SHEET
SHT. No.	

UNLESS OTHERWISE SPECIFIED:
DIMENSIONS ARE IN INCHES
TOLERANCES:
FRACTIONAL: ±1/16
ANGULAR: MACH ±1° BEND ±1°
TWO PLACE DECIMAL ±0.03
THREE PLACE DECIMAL ±0.031

CONTRACT NO.	
DRAWN BY	DATE
ENGINEER	DATE
SOLIDWORKS	AUTOCAD
DO NOT SCALE DRAWING	

COLMAC INDUSTRIES 401 N. Lincoln, Colville, Washington 99114 (509)684-4505		
TITLE: ASSY, CXA PLENUM SHROUD "C" FRAME		
SIZE	DWG. NO.	REV
B	1010CXA-0015	
SCALE: 1:12	UNIT WT.	SHEET 3 OF 3

8 7 6 5 4 3 2 1

1010CXA-0015

9/22/2021